

ACTUAL EXAMPLE SHOWING PROTECTIVE AND TACTICAL WIRE.

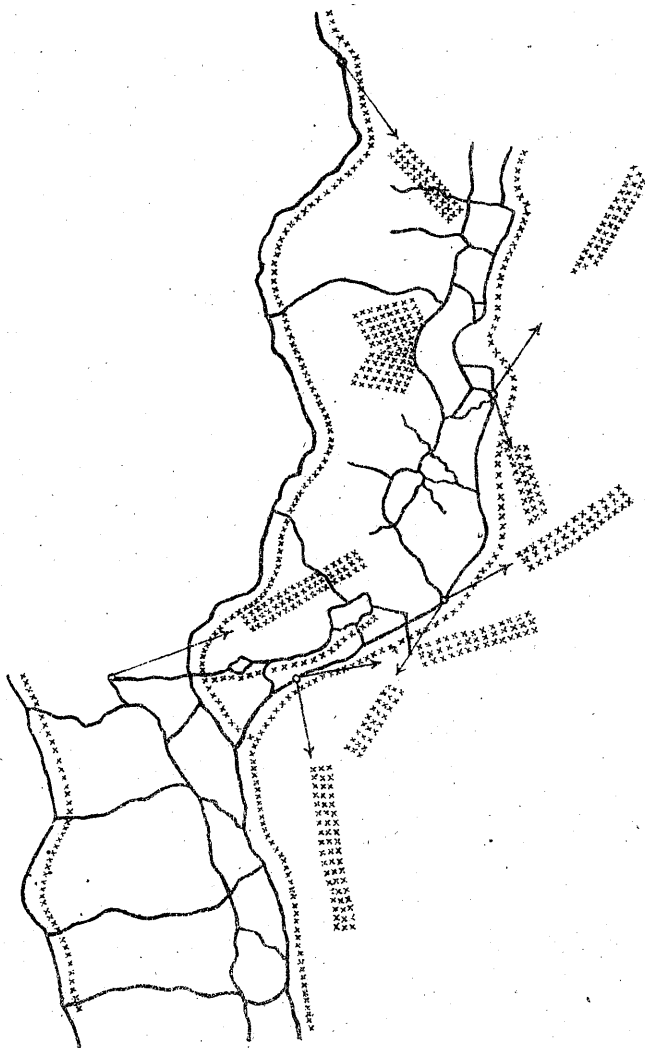

DUG IN WIRE.

Fig. 1



BORROW-PIT FILLED WITH WIRE AND FLOODED.

Fig. 2



DIAGRAM SHOWING HOW TO FINISH OFF
THE ENDS OF THE ENTANGLEMENT AT A GAP

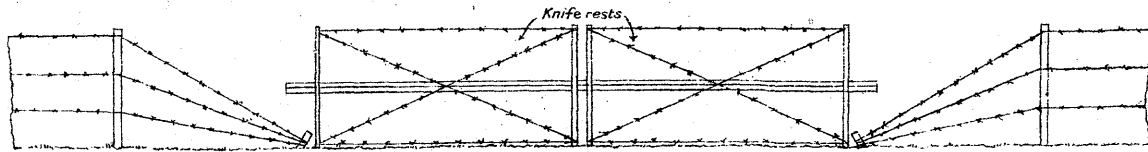

WRONG.

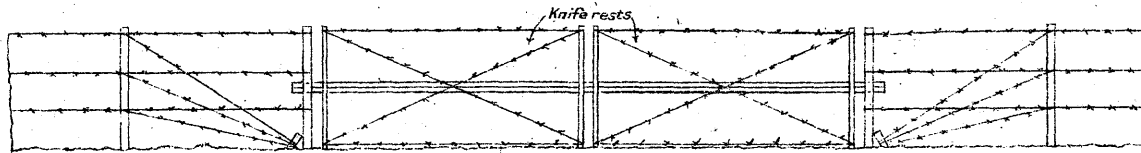

RIGHT

NOTE. Knife Rests must be securely anchored to the entanglement and to each other.

BLOCKING OF ROADS.

TWO BELTS OF WIRE CROSSING A ROAD DIAGONALLY.

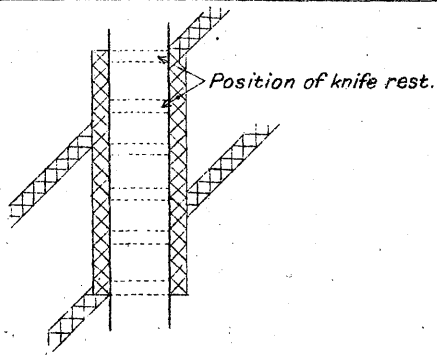

ROAD OPEN PREPARED FOR BLOCKING.

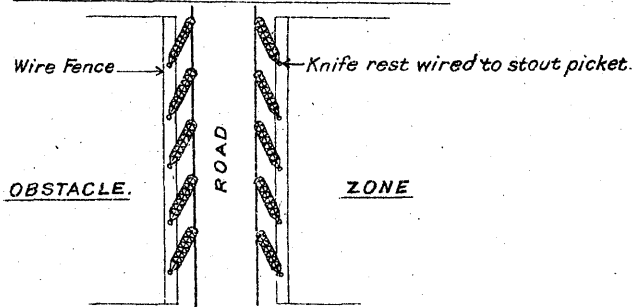

ROAD CLOSED.

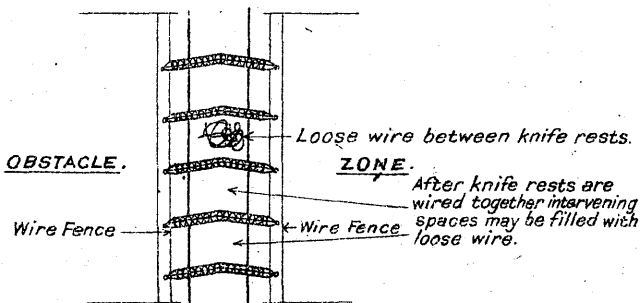

DOUBLE BELT OF CONCERTINAS.

Fig. 3.

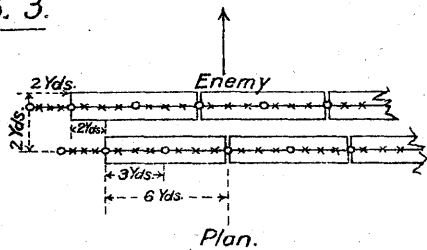

STANDARD FRENCH WIRE ENTANGLEMENT.

Fig. 1.

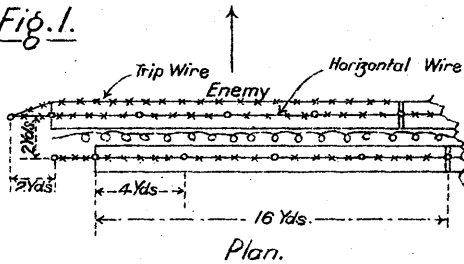

Fig. 4.

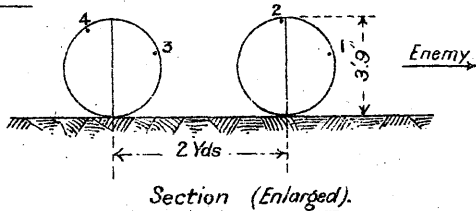
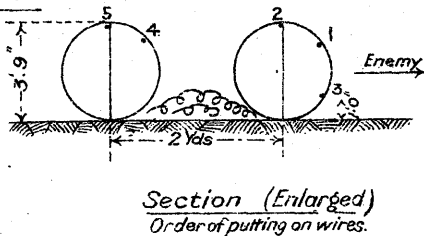
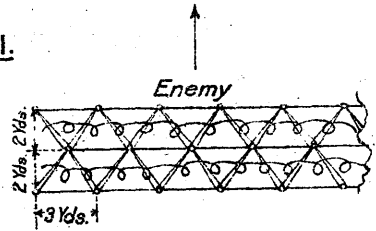

Fig. 2.



STANDARD LOW WIRE ENTANGLEMENT. STANDARD DOUBLE APRON ENTANGLEMENT.

FIG. 1.



PLAN.

FIG. 3.

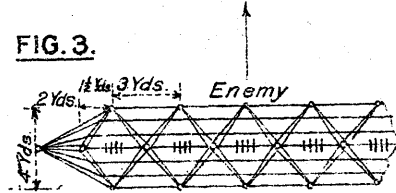

PLAN.

FIG. 2.

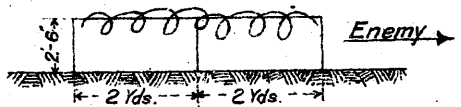

SECTION (Enlarged).

Order of putting on the wire.

FIG. 4.

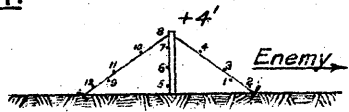

SECTION.

Order of putting on wires.

DOUBLE APRON FENCE.
AS FRAMEWORK FOR WIDE OBSTACLES.

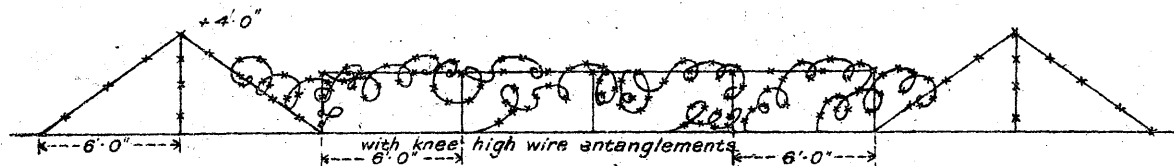
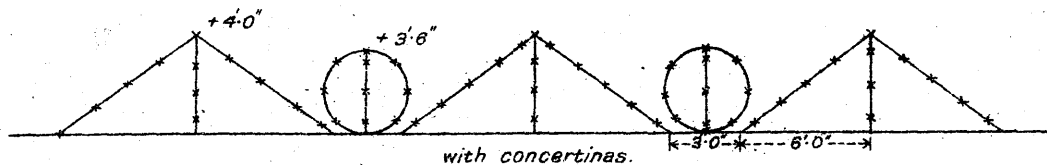
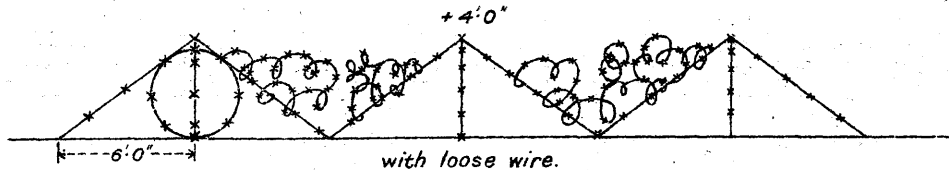
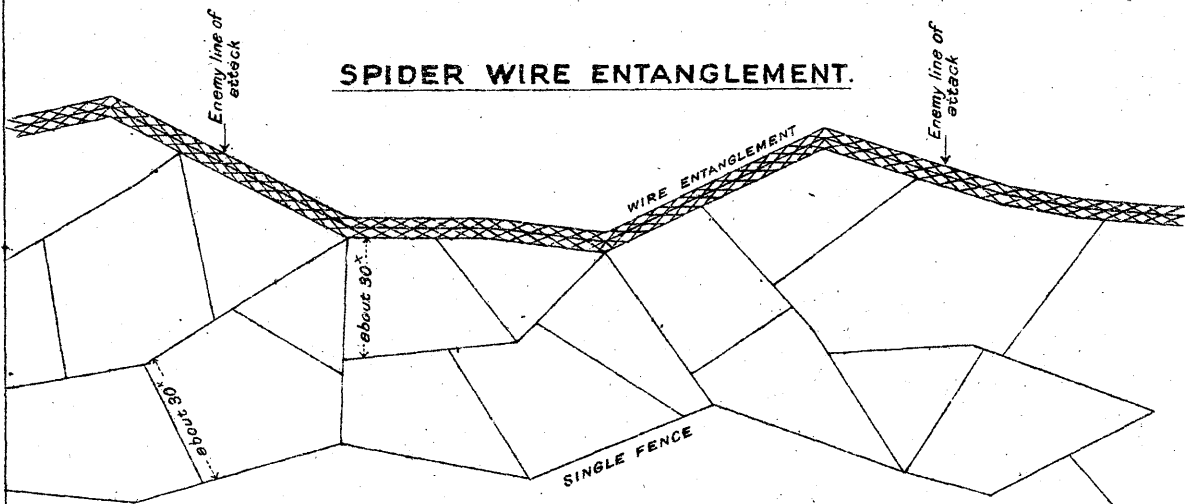

Plate 29.

SPIDER WIRE ENTANGLEMENT.



SINGLE FENCE.

WIRE.

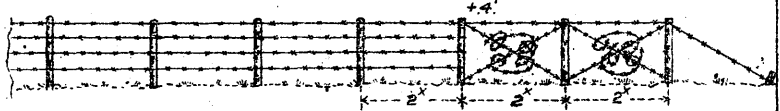
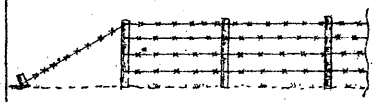

SCREW POSTS FOR WIRE ENTANGLEMENTS.

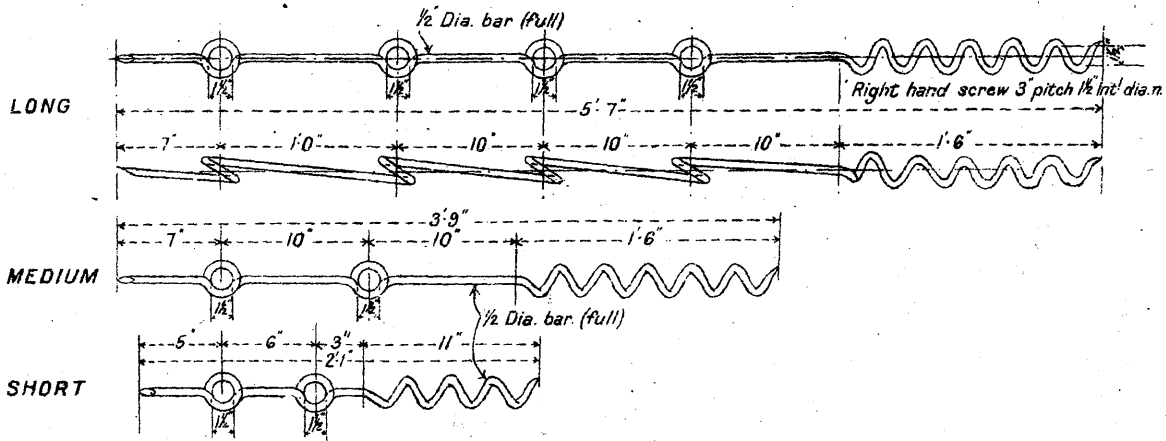

METHOD OF FIXING WIRE TO PICKETS.

FIG. 1.

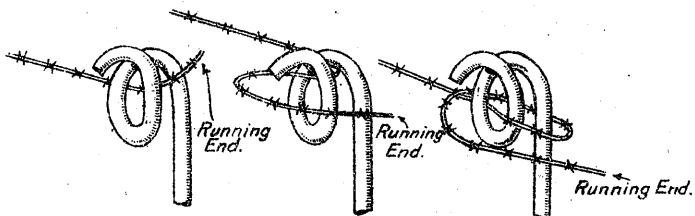

Sketch of Top eye showing wire forced up into it. 2nd Operation showing running end passing down over the point of the eye. Showing wire in the eye and a turn taken below the eye.

FIG. 2.

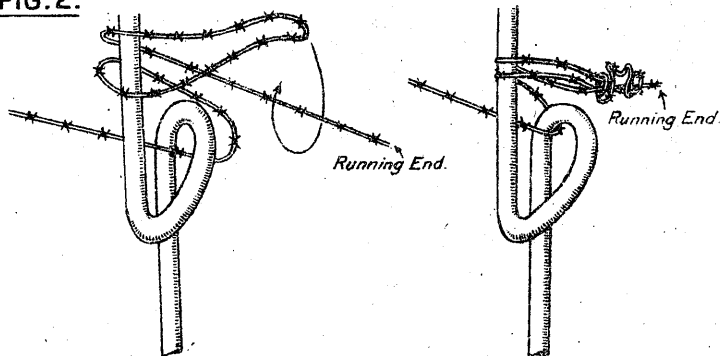

Sketch showing a wire forced up into a lower eye of picket and the bight taken round the picket above the eye.

Showing bight finished off on the running end.

FIG. 3.

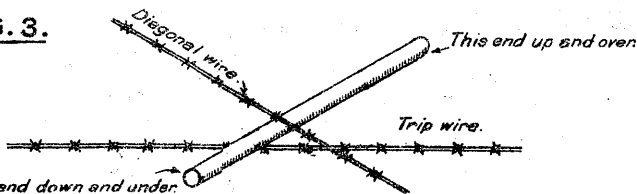

Sketch showing commencement of Windless.

BARRED WIRE CONCERTINAS.

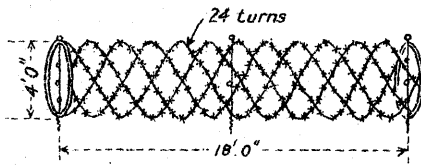
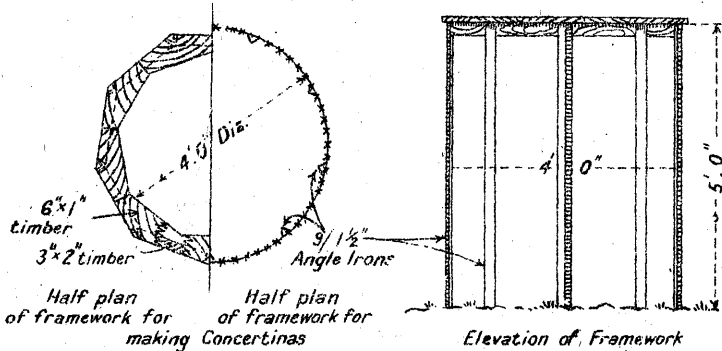

Concertina stretched out

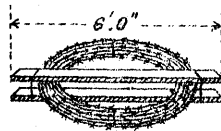

Concertina made up in the standard way.

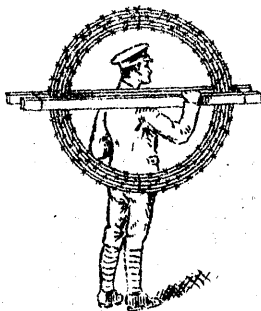

Sketch showing one man carrying Concertina on shoulder.

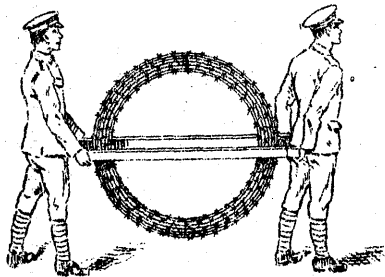

Sketch showing two men carrying Concertina.

KNIFE RESTS.

LARGE KNIFE REST MADE OF WOOD

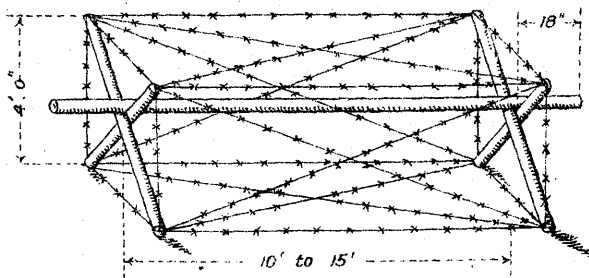

KNIFE REST MADE OF IRON PICKETS.

